

USER MANUAL

MODEL:

DSP-1

Digital Sound Processor



Contents

Introduction	1
Getting Started	1
Overview	2
Typical Applications	3
Defining DSP-1 Digital Sound Processor	4
Connecting DSP-1	5
Connecting to DSP-1 via RS-232	6
Connecting DSP-1 via the Ethernet Port	6
Using the Web Pages	9
Setting the Audio Output Parameters	11
Setting Device Parameters	12
Managing Web Page Security	14
Viewing the About Page	15
Upgrading the Firmware	16
Technical Specifications	17
DSP-1 Performance Graphs	18
Default Communication Parameters	20
Protocol 3000	21
Understanding Protocol 3000	22
Kramer Protocol 3000 Syntax	23
Protocol 3000 Commands	24

Introduction

Welcome to Kramer Electronics! Since 1981, Kramer Electronics has been providing a world of unique, creative, and affordable solutions to the vast range of problems that confront the video, audio, presentation, and broadcasting professional on a daily basis. In recent years, we have redesigned and upgraded most of our line, making the best even better!

Getting Started

We recommend that you:

- Unpack the equipment carefully and save the original box and packaging materials for possible future shipment.
- Review the contents of this user manual.



Go to www.kramerav.com/downloads/DSP-1 to check for up-to-date user manuals, application programs, and to check if firmware upgrades are available (where appropriate).

Achieving the Best Performance

- Use only good quality connection cables (we recommend Kramer high-performance, high-resolution cables) to avoid interference, deterioration in signal quality due to poor matching, and elevated noise levels (often associated with low quality cables).
- Do not secure the cables in tight bundles or roll the slack into tight coils.
- Avoid interference from neighboring electrical appliances that may adversely influence signal quality.
- Position your Kramer **DSP-1** away from moisture, excessive sunlight and dust.



This equipment is to be used only inside a building. It may only be connected to other equipment that is installed inside a building.

Safety Instructions



Caution: There are no operator serviceable parts inside the unit.

Warning: Use only the Kramer Electronics power supply that is provided with the unit.

Warning: Disconnect the power and unplug the unit from the wall before installing.

Recycling Kramer Products

The Waste Electrical and Electronic Equipment (WEEE) Directive 2002/96/EC aims to reduce the amount of WEEE sent for disposal to landfill or incineration by requiring it to be collected and recycled. To comply with the WEEE Directive, Kramer Electronics has made arrangements with the European Advanced Recycling Network (EARN) and will cover any costs of treatment, recycling and recovery of waste Kramer Electronics branded equipment on arrival at the EARN facility. For details of Kramer's recycling arrangements in your particular country go to our recycling pages at www.kramerav.com/support/recycling.

Overview

Congratulations on purchasing your Kramer **DSP-1 Digital Sound Processor**.

DSP-1 enables the control of individual volume per input, 3-band parametric EQ, selectable HPF (High-Pass Filters) at 70Hz and master volume via IP. **DSP-1** is a small form factor and cost-effective solution suitable for a range of audio applications.

DSP-1 provides exceptional quality and advanced and user-friendly operation and control:

- 2-Input mixing with master volume.
- Hi-Pass Filter – Selectable HPF at 70Hz.
- Professional, Studio Grade Signal Conversion Technology – Includes the latest generation 32-bit advanced Digital Analog Converter architecture to achieve excellent dynamic performance and improved tolerance to clock jitter. Maintains the quality of the original audio signal with selectable sampling rates up to 96kHz.
- 3-Band Parametric Equalizer – Frequency, Q-factor & gain control per band.
- Line-Level amplifier for audio gain and attenuation.
- Creates & saves presets.
- Highly cost effective.

Controlling your DSP-1

Control your **DSP-1** via:

- RS-232 serial commands transmitted by a touch screen system, PC, or other serial controller.
- The Ethernet using built-in user-friendly Web pages.

Installing your DSP-1

Install DSP-1 using one of the following methods:

- Attach the rubber feet and place the unit on a flat surface.
- Fasten a bracket (included) on each side of the unit and attach it to a flat surface. For more information go to www.kramerav.com/downloads/DSP-1.
- Mount the unit in a rack using the recommended rack adapter (see www.kramerav.com/product/DSP-1).

Typical Applications

DSP-1 is ideal for the following typical applications:

- Classrooms or educational facilities
- Meeting rooms
- Huddle spaces
- Auditoriums

Defining DSP-1 Digital Sound Processor

This section defines DSP-1.

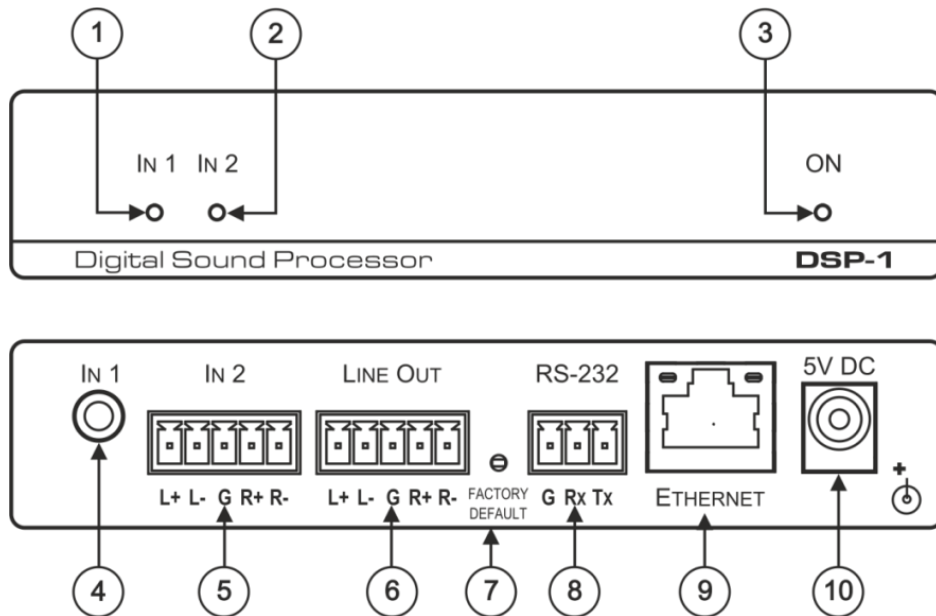

Figure 1: DSP-1 Digital Sound Processor

#	Feature	Function
①	IN 1 LED	Lights green when a signal is present on IN 1.
②	IN 2 LED	Lights green when a signal is present on IN 2.
③	ON LED	Lights green when the device is powered.
④	IN 1 3.5mm Mini Jack	Connect to an unbalanced stereo audio source.
⑤	IN 2 5-pin Terminal Block Connector	Connect to a balanced stereo audio source.
⑥	LINE OUT 5-pin Terminal Block Connector	Connect to a balanced stereo audio acceptor.
⑦	FACTORY DEFAULT Recessed Button	Press and hold while powering the device to reset IP settings to factory default values.
⑧	RS-232 (G, Rx, Tx) 3-pin Terminal Block Connector	Connect to a PC or a serial controller.
⑨	ETHERNET RJ-45 Port	Connect to the Ethernet.
⑩	5V DC	5V DC connector for powering the unit.

Connecting DSP-1

i Always switch off the power to each device before connecting it to your **DSP-1**. After connecting your **DSP-1**, connect its power and then switch on the power to each device.

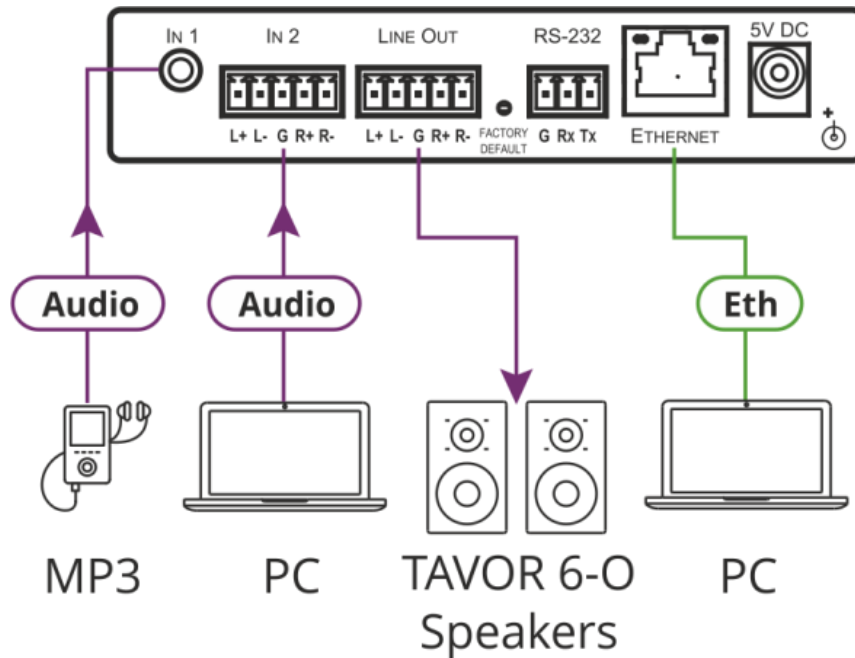

Figure 2: Connecting to the DSP-1 Rear Panel

To connect DSP-1 as illustrated in Figure 2:

1. Connect an unbalanced stereo audio source (for example, an MP3) to the IN 1 3.5mm mini jack (4).
2. Connect a balanced stereo source (for example, from a PC) to the IN 2 5-pin terminal block connector (5).
3. Connect the LINE OUT 5-pin terminal block connector (6) to a balanced stereo audio acceptor (for example, active speakers).
Connect the left speaker to the “L+” and the “L-” terminal block connectors, and the right speaker to the “R+” and the “R-” terminal block connectors.

i Do not ground the speakers.

4. If required, connect to:
 - A PC or serial controller via the RS-232 3-pin terminal block (8).
 - A PC via the ETHERNET RJ-45 port (9).
5. Connect the 5V DC power connector (10) to the power adapter and plug it to the mains electricity.
We recommend that you use only the power adapter that is supplied with this machine.

Connecting to DSP-1 via RS-232

You can connect to the **DSP-1** via an RS-232 connection to the RS-232 port ⁸ using, for example, a PC.

Connect the RS-232 terminal block on the rear panel of the **DSP-1** to a PC/controller, as follows (see [Figure 3](#)):

- TX pin to Pin 2.
- RX pin to Pin 3.
- GND pin to Pin 5.

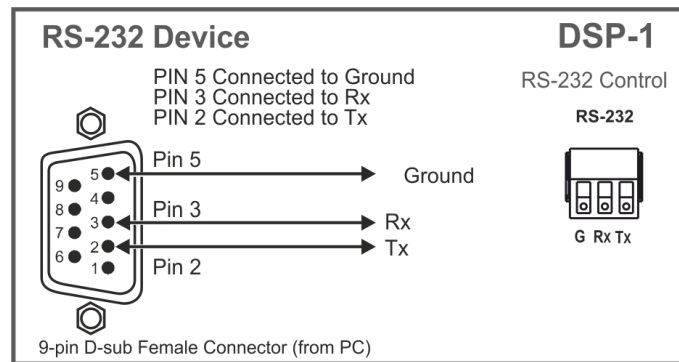

Figure 3: RS-232 Connection

Connecting DSP-1 via the Ethernet Port

You can connect to the **DSP-1** via Ethernet using either of the following methods:

- [Connecting the Ethernet Port Directly to a PC](#) on page 6.
- [Connecting the Ethernet Port via a Network Hub or Switch](#) on page 8.



If you want to connect via a router and your IT system is based on IPv6, speak to your IT department for specific installation instructions.

Connecting the Ethernet Port Directly to a PC

You can connect the Ethernet port of the **DSP-1** directly to the Ethernet port on your PC using a crossover cable with RJ-45 connectors.



This type of connection is recommended for identifying the **DSP-1** with the factory configured default IP address.

After connecting the **DSP-1** to the Ethernet port, configure your PC as follows:

1. Click **Start > Control Panel > Network and Sharing Center**.
2. Click **Change Adapter Settings**.
3. Highlight the network adapter you want to use to connect to the device and click **Change settings of this connection**.

The Local Area Connection Properties window for the selected network adapter appears as shown in [Figure 4](#).

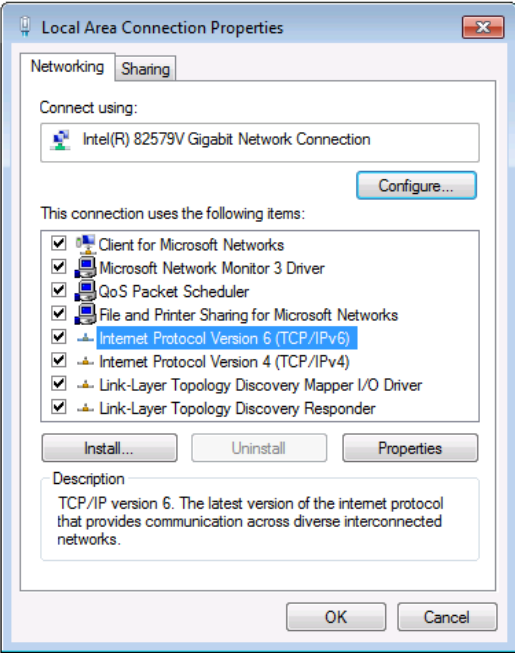

Figure 4: Local Area Connection Properties Window

- 4. Highlight either **Internet Protocol Version 6 (TCP/IPv6)** or **Internet Protocol Version 4 (TCP/IPv4)** depending on the requirements of your IT system.
- 5. Click **Properties**.
The Internet Protocol Properties window relevant to your IT system appears as shown in [Figure 5](#) or [Figure 6](#).

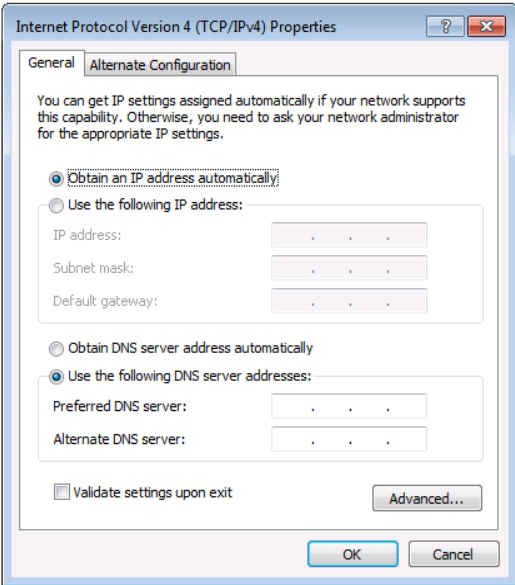

Figure 5: Internet Protocol Version 4 Properties Window

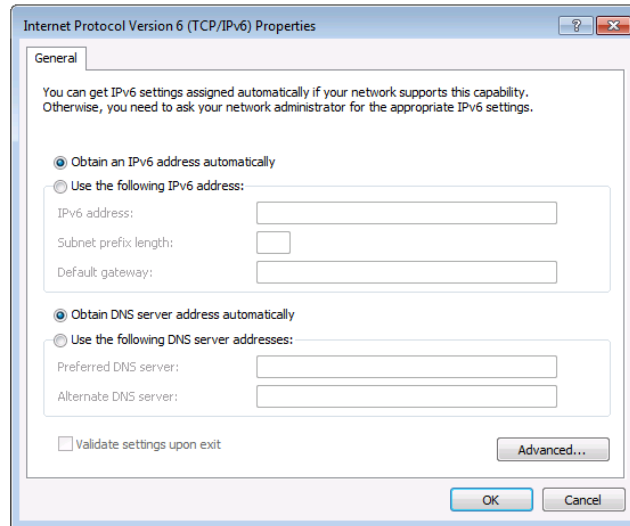

Figure 6: Internet Protocol Version 6 Properties Window

6. Select **Use the following IP Address** for static IP addressing and fill in the details as shown in [Figure 7](#).

For TCP/IPv4 you can use any IP address in the range 192.168.1.1 to 192.168.1.255 (excluding 192.168.1.39) that is provided by your IT department.

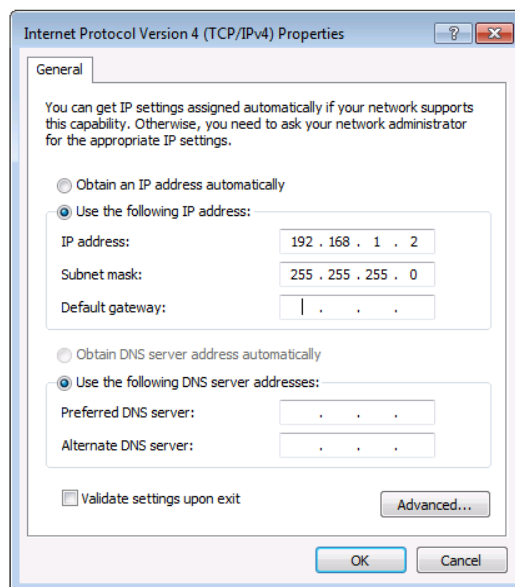

Figure 7: Internet Protocol Properties Window

7. Click **OK**.
8. Click **Close**.

Connecting the Ethernet Port via a Network Hub or Switch

You can connect the Ethernet port of the DSP-1 to the Ethernet port on a network hub or using a straight-through cable with RJ-45 connectors.

Control Configuration via the Ethernet Port

To control several units via Ethernet, connect the Master unit (Device 1) via the Ethernet port to the Ethernet port of your PC. Use your PC provide initial configuration of the settings (see [Connecting DSP-1 via the Ethernet Port](#) on page 6).

Using the Web Pages

- The web pages enable you to control the **DSP-1** via the Ethernet and enable performing the following operations:
- [Setting the Audio Output Parameters](#) on page [11](#).
- [Setting Device Parameters](#) on page [12](#).
- [Managing Web Page Security](#) on page [14](#).
- [Viewing the About Page](#) on page [15](#).

Before attempting to connect:

- Perform the procedures in [Connecting DSP-1 via the Ethernet](#) Port on page [6](#).
- Ensure that your browser is supported.

The following operating systems and Web browsers are supported:

OS	Version	Browser
Windows	7	IE
		Firefox
		Chrome
		Safari
	10	IE
		Edge
		Firefox
		Chrome
Mac	10.11	Safari
iOS	10.3.2	Safari
Android	N/A	N/A

To browse the DSP-1 Web pages:

1. Open your Internet browser.
2. Type the IP address of the device in the address bar of your browser. For example, the default IP address:



Figure 8: Using the Embedded Web Pages – Default IP Address

If the Web pages are password protected, the Authentication window appears:

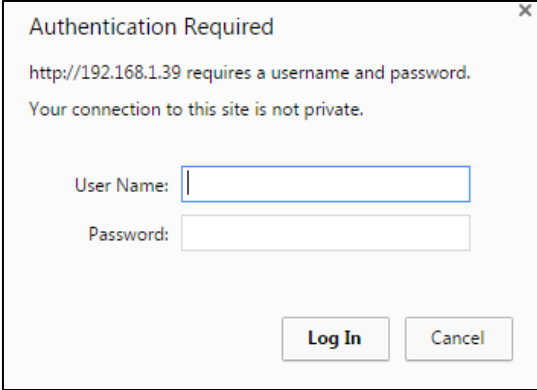

Figure 9: Using the Embedded Web Pages – Authentication Window

- 3. Enter the **User Name** and **Password** (Admin and Admin by-default) and click **OK**. The Output Settings page appears.

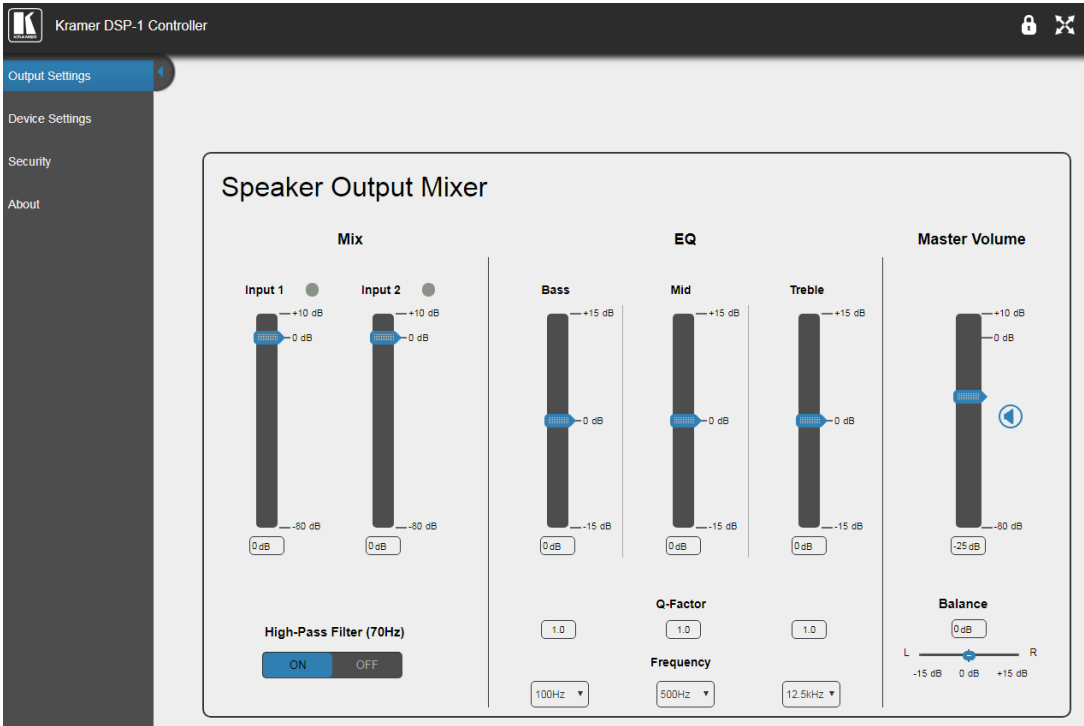

Figure 10: Output Settings Page with Navigation List on Left

- 4. Click the desired Web page or click the arrow to hide the navigation list.

Setting the Audio Output Parameters

The Speaker Output Mixer enables performing the following operations:

- [Mixing the Input Signal Levels](#) on page [11](#).
- [Setting Equalization Levels](#) on page [11](#).
- [Setting the Master Volume and Balance](#) on page [11](#).

Mixing the Input Signal Levels



The indication buttons next to Input 1 and Input 2 appear green when there is an active signal on that input.

To set the Mixing Level:

1. In the Navigation pane, click **Output Settings**.
The Speaker Output Mixer page appears (see [Figure 10](#)).
2. In the Mix column, use the slides to set the mixing level for each input or enter their value below the slides.
3. Set the High-Pass Filter **ON** or **OFF** to cut off frequencies lower than 70Hz.



To save energy, enable the High-Pass Filter when outputting soft background music or speech sources.

Setting Equalization Levels

We recommend that you first set the frequencies, then the Q and finally the Bass, Mid and Treble ranges.

To set EQ levels:

1. In the navigation pane click **Output Settings**. The Speaker Output Mixer page appears.
2. In the EQ column set the following:
 - Frequency: Bass [60Hz, 80Hz, 100Hz or 200Hz], Mid [500Hz, 1kHz, 1.5kHz or 2.5kHz] and Treble [10kHz, 12.5kHz, 15kHz or 17.5kHz] frequency.
 - Q-Factor: Bass, Mid and Treble [0.1 to 16].
The lower the Q value, the wider the bandwidth.
 - Equalization: Bass, Mid and Treble via the slides or enter their value [dB] below the slides.

Setting the Master Volume and Balance

In the Master Volume column:

- Use the slide to set the speaker audio level or enter the value [dB] below the slide.
- Click  to mute/unmute the output volume.
- Set the left right balance on the speaker output.

Setting Device Parameters

The Device Settings Web page shows the device details, such as name, MAC address and firmware version. It also allows the following functions:

- Changing the name of the unit by typing the name in the Unit name text box and clicking **Set** next to the name.
- [Changing the Ethernet Settings](#) on page [12](#).
- [Saving and Loading Settings](#) on page [13](#).
- [Performing a Factory Reset](#) on page [13](#).

Changing the Ethernet Settings

To change the Ethernet settings, if required:

1. In the Navigation pane, click **Device Settings**. The Device Settings page appears:

Device Settings

Unit name

Model **DSP-1**

Firmware version **1.9.47150**

Serial number **5555555522223**

Ethernet Settings

DHCP ON OFF

IP address

Mask address

Gateway address

Mac address **00-01-26-01-00-0f**

UDP port

TCP port

All settings

Figure 11: Device Settings Page

2. Set DHCP to **ON** or **OFF**.
3. If DHCP is set to **OFF**, change any of the parameters (IP Address, Netmask and/or Gateway), if required.
4. Click **Set**.



- After changing the IP address, reload the web page with the new IP address.
- After changing the Mask address you need to restart the **DSP-1**.
- If DHCP is checked, reload the web page with the new IP address.

5. Set the UDP and TCP port numbers and click **Set**.

Saving and Loading Settings

To save a configuration:

1. In the Navigation pane, click **Device Settings**.
The Device Settings page appears (see [Figure 11](#)).
2. Click **Save**. The following message appears:
“Configuration file is ready, [right-click here](#) to download”.
3. Right-click the link ([right-click here](#)) and click **Save link as**.
The configuration is downloaded to your PC.

To load a configuration:

1. In the Navigation pane, click **Device Settings**.
The Device Settings page appears (see [Figure 11](#)).
2. Click **Load** and browse for the configuration file.
3. Click **Open**.
The configuration loads (this process may take a few minutes to complete).
A message indicating that the configuration uploaded successfully appears.

Performing a Factory Reset

To reset the device to its factory default values:

1. In the Navigation pane, click **Device Settings**.
The Device Settings page appears (see [Figure 11](#)).
2. Click **Factory reset**.
A confirmation warning message appears.
3. Click **OK** to start factory reset and follow the instructions on-screen.

Managing Web Page Security

Use the Authentication page to set Web access permission.

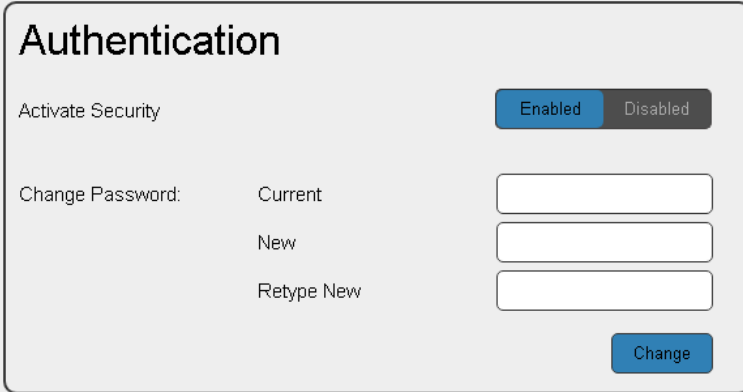

To access Web pages without using the password:

1. In the Navigation pane, click **Security**.
The Authentication page appears (see [Figure 12](#)).



The screenshot shows a web interface titled "Authentication". At the top, there is a section for "Activate Security" with two buttons: "Enabled" (highlighted in blue) and "Disabled". Below this is a "Change Password" section with three input fields labeled "Current", "New", and "Retype New". A "Change" button is located at the bottom right of the form.

Figure 12: Authentication Page

2. Set Activate Security to **Disabled**.
A message prompting for your password appears.
3. Type the current password (Admin by default) and click **OK**.
A message indicating that the password was changed successfully appears.
4. Click **OK**.
The Web page reloads and the web pages are unlocked  .

To access Web pages using the password:

1. In the Navigation pane, click **Security**.
The Authentication page appears (see [Figure 12](#)).
2. Set Activate Security to **Enabled** for Web page password protection.
A confirmation warning message appears:
3. Click **OK**.
The connection is interrupted, and authentication is required to access web pages.

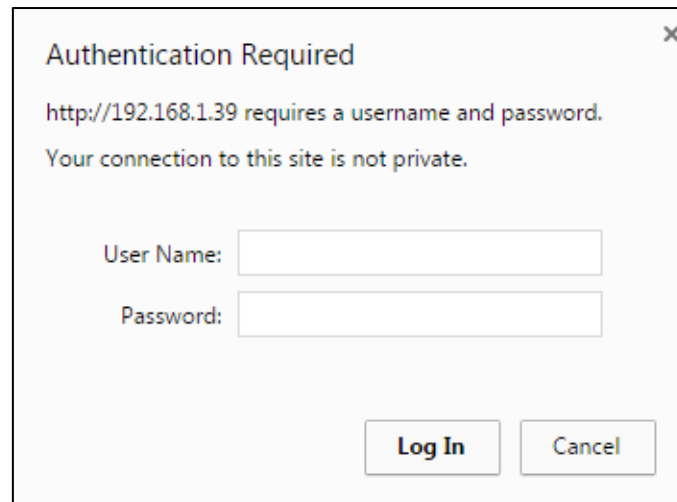



Figure 13: Password Settings Page – Security Log In

4. Type the User Name (Admin, by default) and Password (Admin, by default).
5. Click **Log In**.
6. Select **Security** from the Navigation pane.
The Authentication page appears (see [Figure 12](#)).
7. Type the new authentication password twice in both New and Retype New text boxes.
8. Click **Change**.
A confirmation warning message appears.
9. Click **OK**. The following message appears.
A message indicating that the password was changed successfully appears.
10. Click **OK**.

The web pages are locked  .

Viewing the About Page

The About page lets you view the web page version and Kramer Electronics Ltd details.

Upgrading the Firmware

You can upgrade the **DSP-1** via the Ethernet or RS-232 using Kramer **K-UPLOAD** tool.



The latest firmware version and the latest version of **K-UPLOAD** and installation instructions can be downloaded from the Kramer Web site at www.kramerav.com/downloads/DSP-1.

Technical Specifications

Inputs	Balanced Stereo Audio	On a 5-pin terminal block connector
	Unbalanced Stereo Audio	On a 3.5mm mini jack
Output	Balanced Stereo Audio	On a 5-pin terminal block connector
Ports	RS-232	On a 3-pin terminal block connector
	Ethernet	On an RJ-45 female connector
Audio	Frequency Response	20Hz to 20kHz, ± 0.3 dB
	Signal to Noise Ratio	>110dB, 20Hz to 20kHz, at unity gain (unweighted)
	THD+N	<0.01%, 20Hz to 20kHz, at unity gain
	Crosstalk	< -85dB, 20Hz to 20kHz
	Input Impedance	10K Ω
	Output Impedance	150 Ω
Supported Web Browsers	Windows 7	Internet Explorer, Firefox, Chrome, Safari
	Windows 10	Internet Explorer, Edge, Firefox, Chrome
	MAC 10.11	Safari
	iOS 10.3.2	Safari
	Android	N/A
Power	Consumption	5V DC, 350mA
	Source	5V DC, 4A
Environmental Conditions	Operating Temperature	0° to +40°C (32° to 104°F)
	Storage Temperature	-40° to +70°C (-40° to 158°F)
	Humidity	10% to 90%, RHL non-condensing
Regulatory Compliance	Safety	CE
	Environmental	RoHs, WEEE
Enclosure	Size	Tool
	Type	Aluminum
	Cooling	Convection ventilation
General	Net Dimensions (W, D, H)	12cm x 7.2cm x 2.4cm (4.7" x 2.8" x 0.9")
	Shipping Dimensions (W, D, H)	15.7cm x 12cm x 8.7cm (6.2" x 4.7" x 3.4")
	Net Weight	0.2kg (0.4lbs)
	Shipping Weight	0.6kg (1.3lbs) approx.
Accessories	Included	Power adapter and cord
	Optional	For optimum range and performance use the recommended Kramer cables available at www.kramerav.com/product/DSP-1
Specifications are subject to change without notice at www.kramerav.com		

DSP-1 Performance Graphs

The following graphs present the DSP-1 performance.

DSP-1 Frequency Response

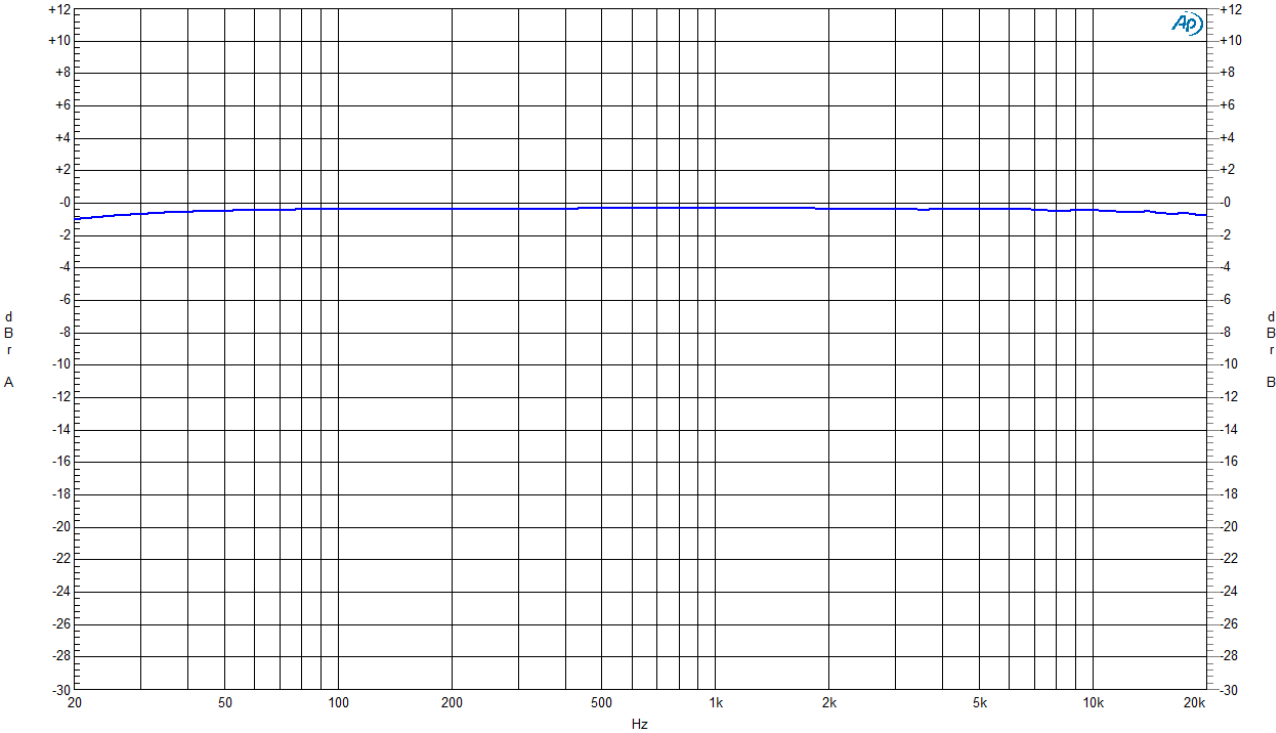

Figure 14: Frequency Response

DSP-1 Signal to Noise Ratio

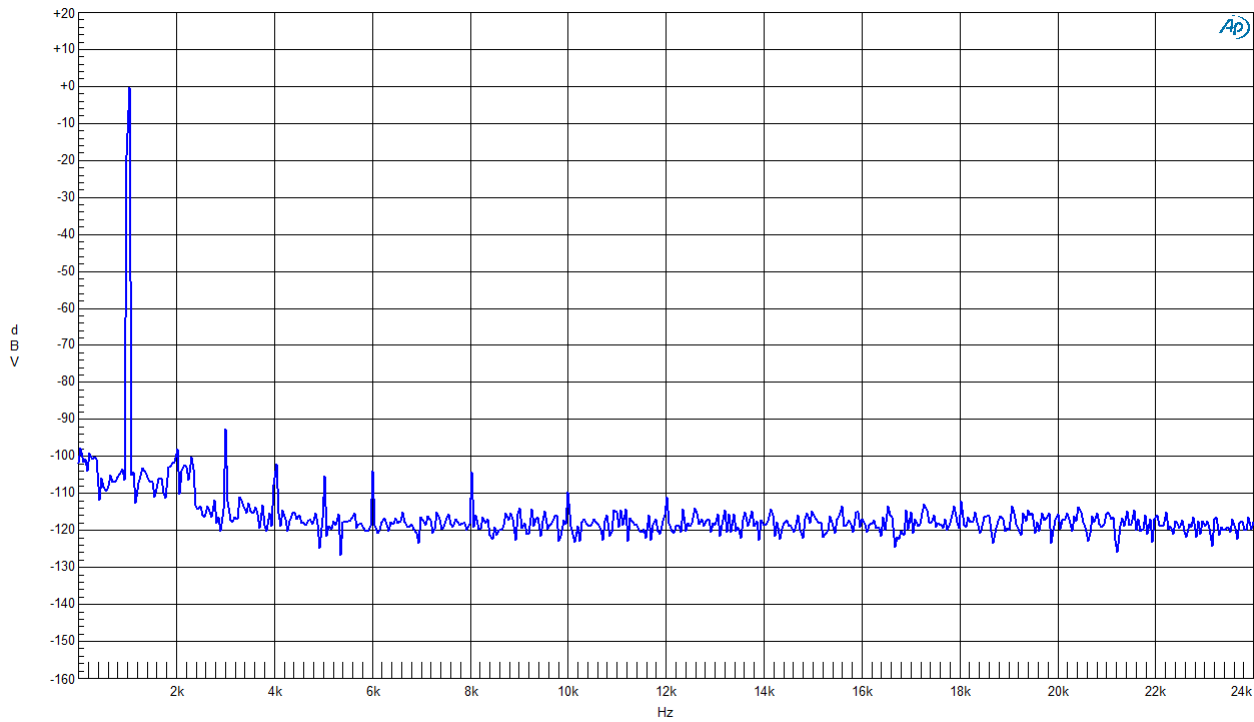

Figure 15: Signal to Noise Ratio

DSP-1 THD + N

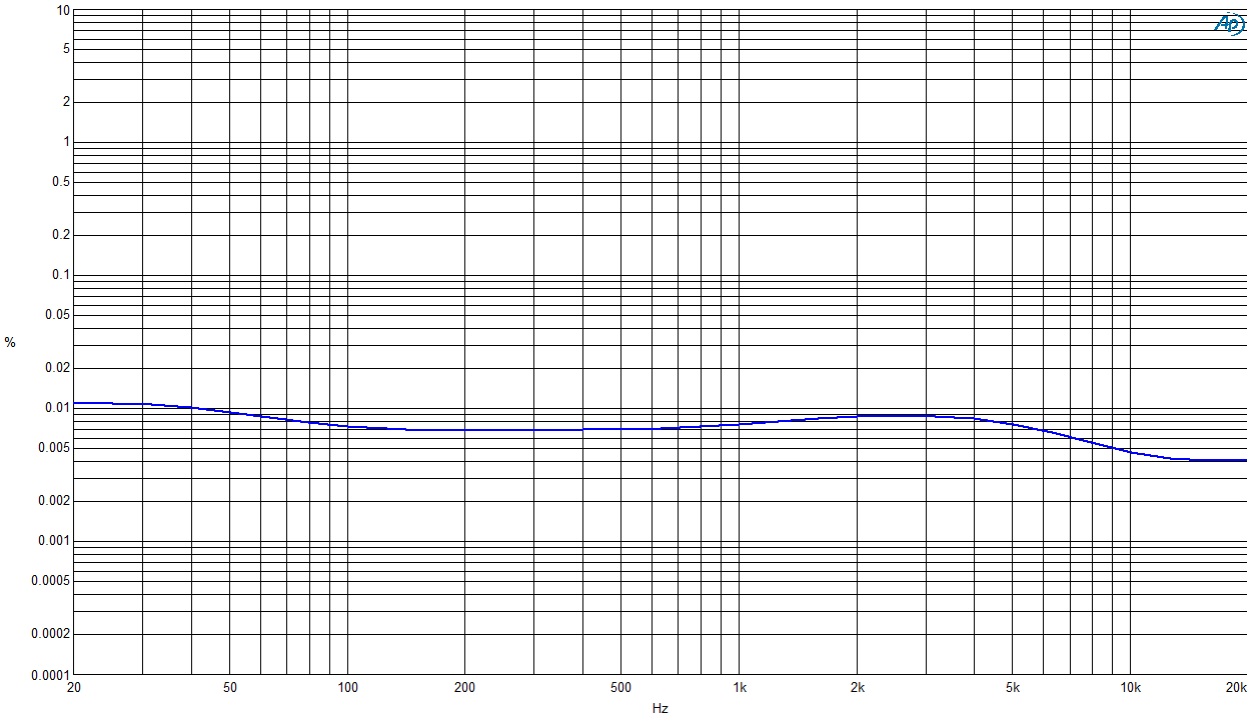

Figure 16: THD + N

DSP-1 Crosstalk

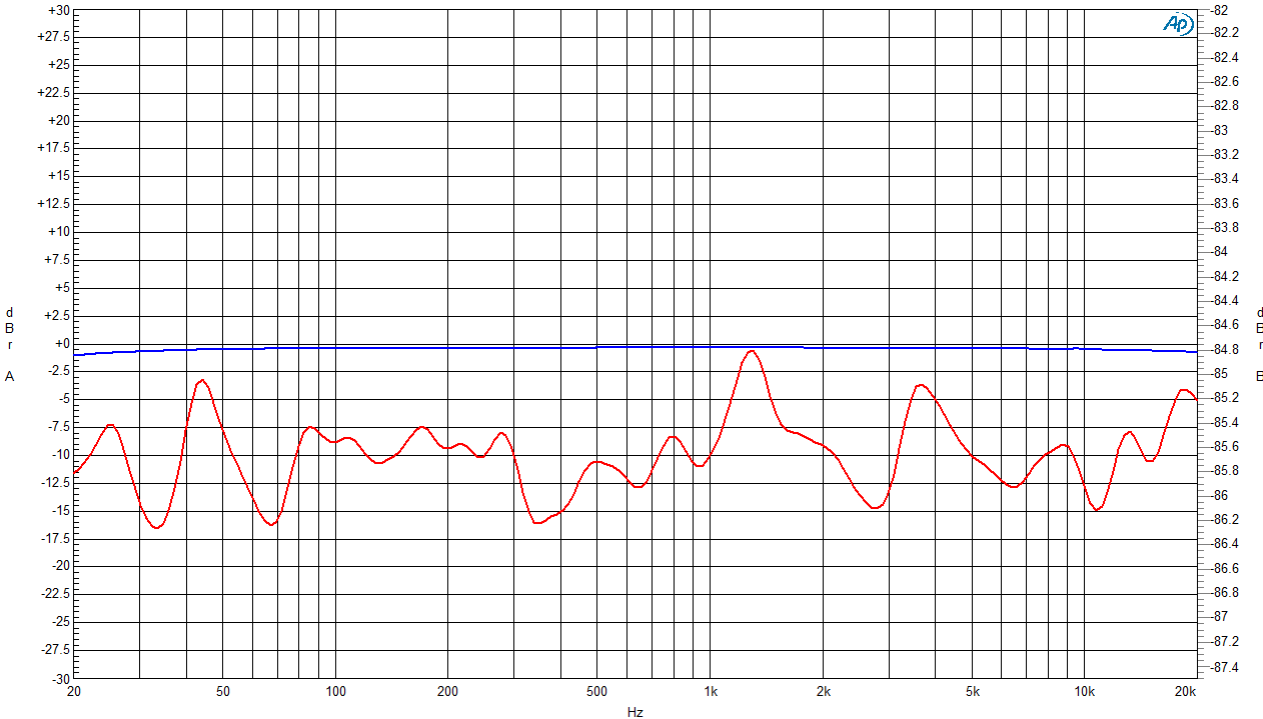

Figure 17: Crosstalk

Default Communication Parameters

RS-232	
Baud Rate:	115,200
Data Bits:	8
Stop Bits:	1
Parity:	None
Command Format:	ASCII
Example (Change the volume of input 2 to -10 DB):	#X-AUD-LVL 1, 2, -10
TCP/IP Parameters	
IP Address:	192.168.1.39
Subnet mask:	255.255.000.000
Default gateway:	192.168.0.1
TCP Port #:	5000
Maximum TCP Ports:	Unlimited
UDP Port #:	50000
Maximum UDP Ports:	Unlimited
Default Security Settings	
Username / Password:	Admin / Admin
Full Factory Reset	
Protocol 3000:	Use "#FACTORY" command and use "#RESET" to restore the factory default values.
Web pages:	Go to: Device Settings-> Factory reset
Rear panel button:	Press and hold FACTORY DEFAULT while powering the device to reset IP settings to factory default values.

Protocol 3000

The **DSP-1 Digital Sound Processor** can be operated using the Kramer Protocol 3000 serial commands. The command framing varies according to how you interface with the **DSP-1**.

Generally, a basic video input switching command that routes a layer 1 video signal to HDMI out 1 from HDMI input 2 (ROUTE 1, 1, 2), is entered as follows:

- Terminal communication software, such as Hercules:

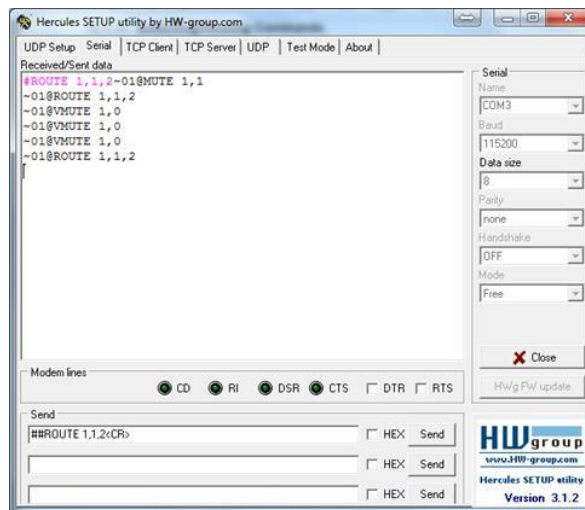

The framing of the command varies according to the terminal communication software.

- K-Touch Builder (Kramer software):

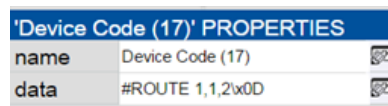

- K-Config (Kramer configuration software):

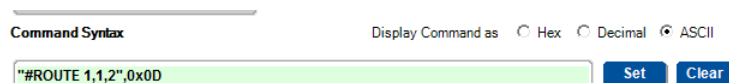

All the examples provided in this section are based on using the K-Config software.

You can enter commands directly using terminal communication software (e.g., Hercules) by connecting a PC to the serial or Ethernet port, depending on your device. To enter **CR** press the Enter key (**LF** is also sent but is ignored by the command parser).

Commands sent from various non-Kramer controllers (e.g., Crestron) may require special coding for some characters (such as, /X##). For more information, refer to your controller's documentation.

For more information about Protocol 3000 commands, see:

- [Understanding Protocol 3000](#) on page [22](#).
- [Kramer Protocol 3000 Syntax](#) on page [23](#).
- [Protocol 3000 Commands](#) on page [24](#).

Understanding Protocol 3000

Protocol 3000 commands are structured according to the following:

- **Command** – A sequence of ASCII letters (A-Z, a-z and -). A command and its parameters must be separated by at least one space.
- **Parameters** – A sequence of alphanumeric ASCII characters (0-9, A-Z, a-z and some special characters for specific commands). Parameters are separated by commas.
- **Message string** – Every command entered as part of a message string begins with a message starting character and ends with a message closing character.



A string can contain more than one command. Commands are separated by a pipe (|) character.

- **Message starting character:**
 - # – For host command/query
 - ~ – For device response
- **Device address** – K-NET Device ID followed by @ (optional, K-NET only)
- **Query sign** – ? follows some commands to define a query request
- **Message closing character:**
 - CR – Carriage return for host messages (ASCII 13)
 - CR LF – Carriage return for device messages (ASCII 13) and line-feed (ASCII 10)
- **Command chain separator character** – Multiple commands can be chained in the same string. Each command is delimited by a pipe character (|). When chaining commands, enter the message starting character and the message closing character only at the beginning and end of the string.



Spaces between parameters or command terms are ignored. Commands in the string do not execute until the closing character is entered. A separate response is sent for every command in the chain.

Kramer Protocol 3000 Syntax

The Kramer Protocol 3000 syntax uses the following delimiters:

- **CR** = Carriage return (ASCII 13 = 0x0D)
- **LF** = Line feed (ASCII 10 = 0x0A)
- **SP** = Space (ASCII 32 = 0x20)

Some commands have short name syntax in addition to long name syntax to enable faster typing. The response is always in long syntax.

The Protocol 3000 syntax is in the following format:

- **Host Message Format:**

Start	Address (optional)	Body	Delimiter
#	<i>Device_id@</i>	Message	CR

- **Simple Command** – Command string with only one command without addressing:

Start	Body	Delimiter
#	Command SP <i>Parameter_1,Parameter_2,...</i>	CR

- **Command String** – Formal syntax with command concatenation and addressing:

Start	Address	Body	Delimiter
#	<i>Device_id@</i>	Command_1 <i>Parameter1_1,Parameter1_2,...</i> Command_2 <i>Parameter2_1,Parameter2_2,...</i> Command_3 <i>Parameter3_1,Parameter3_2,...</i> ...	CR

- **Device Message Format:**

Start	Address (optional)	Body	Delimiter
~	<i>Device_id@</i>	Message	CR LF

- **Device Long Response** – Echoing command:

Start	Address (optional)	Body	Delimiter
~	<i>Device_id@</i>	Command SP [<i>Param1 Param2 ...</i>] result	CR LF

Protocol 3000 Commands

This section includes the following commands:

- [System Commands](#) on page [24](#).
- [Audio Commands](#) on page [28](#).
- [Communication Commands](#) on page [34](#).

System Commands

All devices running Protocol 3000 use these commands.

Command	Description
#	Protocol handshaking
BUILD-DATE?	Get device build date
FACTORY	Reset to factory default configuration
HELP	Get command list
MODEL?	Get device model
PROT-VER?	Get device protocol version
RESET	Reset device
SN?	Get device serial number
NAME	Set/get machine (DNS) name

#

Functions		Permission	Transparency
Set:	#	End User	Public
Get:	-	-	-
Description		Syntax	
Set:	Protocol handshaking	#CR	
Get:	-	-	
Response			
~nn@SPOKCR LF			
Notes			
Validates the Protocol 3000 connection and gets the machine number Step-in master products use this command to identify the availability of a device			
K-Config Example			
`#",0x0D			

BUILD-DATE?

Functions		Permission	Transparency
Set:	–	–	–
Get:	BUILD-DATE?	End User	Public
Description		Syntax	
Set:	–	–	
Get:	Get device build date	# BUILD-DATE? CR	
Response			
~nn@ BUILD-DATE SPdateSPtimeCR LF			
Parameters			
date – Format: YYYY/MM/DD where YYYY = Year, MM = Month, DD = Day			
time – Format: hh:mm:ss where hh = hours, mm = minutes, ss = seconds			
K-Config Example			
"#BUILD-DATE?", 0x0D			

FACTORY

Functions		Permission	Transparency
Set:	FACTORY	End User	Public
Get:	–	–	–
Description		Syntax	
Set:	Reset device to factory default configuration	# FACTORY CR	
Get:	–	–	
Response			
~nn@ FACTORY SPOKCR LF			
Notes			
This command deletes all user data from the device. The deletion can take some time. Your device may require powering off and powering on for the changes to take effect.			
K-Config Example			
"#FACTORY", 0x0D			

HELP

Functions		Permission	Transparency
Set:	–	–	–
Get:	HELP	End User	Public
Description		Syntax	
Set:	–	–	
Get:	Get command list or help for specific command	2 options: 1. # HELP CR 2. # HELP SPcommand_nameCR	
Response			
1. Multi-line: ~nn@Device available protocol 3000 commands : CR LFcommand,SPcommand...CR LF To get help for command use: HELP (COMMAND_NAME)CR LF			
2. Multi-line: ~nn@ HELP SPcommand : CR LFdescriptionCR LFUSAGE : usageCR LF			
Notes			
To get help for a specific command use: HELP [SP]COMMAND_NAME[CR LF]			
K-Config Example			
"#HELP", 0x0D			

MODEL?

Functions		Permission	Transparency
Set:	–	–	–
Get:	MODEL?	End User	Public
Description		Syntax	
Set:	–	–	
Get:	Get device model	# MODEL? CR	
Response			
~nn@ MODEL SP <i>model_name</i> CR LF			
Parameters			
<i>model_name</i> – string of up to 19 printable ASCII chars			
Notes			
This command identifies equipment connected to Step-in master products and notifies of identity changes to the connected equipment. The Matrix saves this data in memory to answer REMOTE-INFO requests			
K-Config Example			
"#MODEL?", 0x0D			

PROT-VER?

Functions		Permission	Transparency
Set:	–	–	–
Get:	PROT-VER?	End User	Public
Description		Syntax	
Set:	–	–	
Get:	Get device protocol version	# PROT-VER? CR	
Response			
~nn@ PROT-VER SP3000: <i>version</i> CR LF			
Parameters			
<i>version</i> – XX.XX where X is a decimal digit			
K-Config Example			
"#PROT-VER?", 0x0D			

RESET

Functions		Permission	Transparency
Set:	RESET	Administrator	Public
Get:	–	–	–
Description		Syntax	
Set:	Reset device	# RESET CR	
Get:	–	–	
Response			
~nn@ RESET SPOKCR LF			
Notes			
To avoid locking the port due to a USB bug in Windows, disconnect USB connections immediately after running this command. If the port was locked, disconnect and reconnect the cable to reopen the port.			
K-Config Example			
"#RESET", 0x0D			

SN?

Functions		Permission	Transparency
Set:	–	–	–
Get:	SN?	End User	Public
Description		Syntax	
Set:	–	–	
Get:	Get device serial number	# SN? CR	
Response			
~nn@ SN SPserial_numberCR LF			
Parameters			
serial_number – 14 decimal digits, factory assigned			
K-Config Example			
"#SN?",0x0D			

NAME

Functions		Permission	Transparency
Set:	NAME	Administrator	Public
Get:	NAME?	End User	Public
Description		Syntax	
Set:	Set machine (DNS) name	# NAME SPmachine_nameCR	
Get:	Get machine (DNS) name	# NAME? CR	
Response			
Set: ~nn@ NAME SPmachine_nameCR LF			
Get: ~nn@ NAME? SPmachine_nameCR LF			
Parameters			
machine_name – string of up to 15 alpha-numeric chars (can include hyphen, not at the beginning or end)			
Notes			
The machine name is not the same as the model name. The machine name is used to identify a specific machine or a network in use (with DNS feature on)			
K-Config Example			
Set the DNS name of the device to "room-442": "#NAME room-442",0x0D			

Audio Commands

These commands are used by audio devices running Protocol 3000.

Command	Description
AUD-FILTER	Set/get filter/state
AUD-IN-CONF	Set/get threshold and time
AUD-LVL	Set/get audio level in specific amplifier stage
AUD-MIX	Set/get mixer level
AUD-SIGNAL?	Get audio input signal status
BALANCE	Set/get balance level
EQ-FREQ	Set/get equalizer center
EQ-LVL	Set/get equalization level
EQ-Q	Set/get Q level
MUTE	Set/get audio mute

AUD-FILTER

Functions	Permission	Transparency
Set: AUD-FILTER	End User	Public
Get: AUD-FILTER?	End User	Public
Description	Syntax	
Set: Set filter	#AUD-FILTERSP <i>Channel,FilterType,Freq,State</i> CR	
Get: Get filter state	#AUD-FILTER?SP <i>Channel</i> CR	
Response		
~nn@AUD-FILTERSP <i>Channel,FilterType,Freq,State</i> CR LF		
Parameters		
<i>Channel</i> – 1 (LINE OUT)		
<i>FilterType</i> – Filter type: 0 (High pass filter)		
<i>Freq</i> – Filter frequency: 70		
<i>State</i> – 1 (On), 0 (Off)		
Notes		
T=Treble, M=Middle, B=Bass		
K-Config Example		
Set the audio filter on to 70Hz high pass filter: "#AUD-FILTER 1,0,70,1",0x0D		

AUD-IN-CONF

Functions		Permission	Transparency
Set:	AUD-IN-CONF	End User	Public
Get:	AUD-IN-CONF?	End User	Public
Description		Syntax	
Set:	Set threshold and time to indicate when signal is presents or not.	#AUD-IN-CONF SP <i>Channel,ThresholdDbLevel,TrigTimeDelay</i> CR	
Get:	Get threshold and time	#AUD-IN-CONF? CR <i>Channel</i>	
Response			
~nn@AUD-IN-CONF SP <i>Channel,ThresholdDbLevel,TrigTimeDelay</i> CR LF			
Parameters			
<i>Channel</i> – 1 (LINE OUT)			
<i>ThresholdDbLevel</i> – input level indicating when a signal is not present, range -100 to 0dB			
<i>TrigTimeDelay</i> – 10 (fixed)			
K-Config Example			
Set the LINE OUT threshold level and time: "#AUD-IN-CONF 1, -50, 10", 0x0D			

AUD-LVL

Functions		Permission	Transparency
Set:	AUD-LVL	End User	Public
Get:	AUD-LVL?	End User	Public
Description		Syntax	
Set:	Set volume level	#AUD-LVLSP <i>stage,channel,volume,mutebehavior</i> CR	
Get:	Get volume level	#AUD-LVL?SP <i>stage,channel</i> CR	
Response			
~nn@AUD-LVLSP <i>stage,channel,volume</i> CR LF			
Parameters			
<i>stage</i> – 1 (For output processing)			
<i>channel</i> – 1 (LINE OUT)			
<i>volume</i> --80db to 10dB (Set volume level), -- (Decrease volume), ++ (Increase volume) or by a set dB value			
<i>mutebehavior</i> – optional, 1 (changing the volume does not affect the mute state)			
K-Config Example			
Set the LINE OUT audio level to -50dB: "#AUD-LVL 1,1,-50",0x0D			
Increase the LINE OUT audio by 2dB: "#AUD-LVL 1,1,++2",0x0D			
Decrease the LINE OUT audio: "#AUD-LVL 1,1,--",0x0D			

AUD-MIX

Functions		Permission	Transparency
Set:	AUD-MIX	End User	Public
Get:	AUD-MIX?	End User	Public
Description		Syntax	
Set:	Set mixer level	#AUD-MIXSP <i>channel,knob,level</i> CR	
Get:	Get mixer level	#AUD-MIX?SP <i>channel,knob</i> CR	
Response			
~nn@AUD-MIXSP <i>channel,knob,level</i> CR LF			
Parameters			
<i>channel</i> – 1			
<i>knob</i> – mixer knob (INPUT) number: 1 (knob 1), 2 (knob 2)			
<i>level</i> – mixer level: -80 to 10dB			
K-Config Example			
Set the input mixing level of IN 2 on the speaker output to -48dB: "#AUD-MIX 1,2,-48",0x0D			

AUD-SIGNAL

Functions		Permission	Transparency
Set:	–	–	–
Get:	AUD-SIGNAL?	End User	Public
Description		Syntax	
Set:	–	–	
Get:	Get audio input signal status	# AUD-SIGNAL? <i>SP</i> <i>inp_id</i> CR	
Response			
~ <i>nn</i> @ AUD-SIGNAL <i>SP</i> <i>inp_id,status</i> CR LF			
Parameters			
<i>inp_id</i> – input number: 1 (IN 1), 2 (IN 2)			
<i>status</i> – 0 (OFF, no signal), 1 (ON, signal present)			
Response Triggers			
After execution, response is sent to the com port from which the Get was received Response is sent to all com ports if audio status state was changed on any input			
K-Config Example			
get the status of IN 1: "#AUD-SIGNAL? 1",0x0D			

BALANCE

Functions		Permission	Transparency
Set:	BALANCE	End User	Public
Get:	BALANCE?	End User	Public
Description		Syntax	
Set:	Set balance level	# BALANCE <i>SP</i> <i>channel,balancelevel</i> CR	
Get:	Get balance level	# BALANCE? <i>SP</i> <i>channel</i> CR	
Response			
~ <i>nn</i> @ BALANCE <i>SP</i> <i>channel,balance_level</i> CR LF			
Parameters			
<i>channel</i> – 1 (LINE OUT)			
<i>balancelevel</i> – -15 to +15 (audio parameter in Kramer units, minus sign precedes negative values)			
++ increase current value			
-- decrease current value			
K-Config Example			
Set the LINE OUT balance to +12: "#BALANCE 1,12",0x0D			

EQ-FREQ

Functions		Permission	Transparency
Set:	EQ-FREQ	End User	Public
Get	EQ-FREQ?	End User	Public
Description		Syntax	
Set:	Set equalizer frequency	#EQ- FREQSP Stage,Channel,EqType,EqFreqCR	
Get:	Get equalizer frequency	#EQ- FREQ?SP Stage,Channel,EqTypeCR	
Response			
~nn@EQ- FREQSP Stage,Channel,EqType,EqFreqCR LF			
Parameters			
<i>Stage</i> – 1 (Output) <i>Channel</i> – 1 (LINE OUT) <i>EqType</i> – 0 (Bass), 1 (Middle), 2 (Treble) <i>EqFreq</i> – 0 (T: 10kHz, M: 500Hz, B: 60Hz), 1 (T: 12.5kHz, M: 1kHz, B: 80Hz), 2 (T: 15kHz, M: 1.5kHz, B: 100Hz), 3 (T: 17.5kHz, M: 2.5kHz, B: 200Hz)			
Notes			
T=Treble, M=Middle, B=Bass			
K-Config Example			
Set LINE OUT frequency on the bass to 200Hz: "#EQ-FREQ 1,1,0,3",0x0D			

EQ-LVL

Functions		Permission	Transparency
Set:	EQ-LVL	End User	Public
Get:	EQ-LVL?	End User	Public
Description		Syntax	
Set:	Set equalization level	#EQ-LVLSP Stage,Channel,EqType,LevelCR	
Get :	Get equalization level	#EQ-LVL?SP Stage,Channel,EqTypeCR	
Response			
~nn@EQ-LVLSP Stage,Channel,EqType,LevelCR LF			
Parameters			
<i>Stage</i> – 1 (output processing) <i>Channel</i> – 1 (LINE OUT) <i>EqType</i> – 0 (Bass), 1 (Middle), 2 (Treble) <i>Level</i> –equalizer level in dB: -15 to 15			
K-Config Example			
Set Bass EQ level of LINE OUT to 12dB: "#EQ-LVL 1,1,0,12",0x0D			

EQ-Q

Functions		Permission	Transparency
Set:	EQ-Q	End User	Public
Get:	EQ-Q?	End User	Public
Description		Syntax	
Set:	Set Q level	#EQ-QSPChannel,EqType,Q_levelCR	
Get:	Get Q level	#EQ-Q?SPChannel,EqTypeCR	
Response			
~nn@EQ-QSPChannel,EqType,Q_levelCR LF			
Parameters			
Channel – 1 (LINE OUT) EqType – 0 (Bass), 1 (Middle), 2 (Treble) Q_level – 0 to 15 (Q level)			
K-Config Example			
Set LINE OUT treble Q level to 8: "#EQ-Q 1,2,8",0x0D			

MUTE

Functions		Permission	Transparency
Set:	MUTE	End User	Public
Get:	MUTE?	End User	Public
Description		Syntax	
Set:	Set audio mute	#MUTESPchannel,mute_modeCR	
Get:	Get audio mute	#MUTE?SPchannelCR	
Response			
~nn@MUTESPchannel,mute_modeCR LF			
Parameters			
channel – 1 (LINE OUT) mute_mode – 0 (Off), 1 (On)			
K-Config Example			
Set LINE OUT to mute: "#MUTE 1,1",0x0D			

Communication Commands

These commands are used by network devices running Protocol 3000.

Command	Description
NET-CONFIG	Set/get a network configuration
ETH-PORT	Set/get Ethernet port protocol
NET-DHCP	Set/get DHCP mode
NET-MAC?	Get MAC address

NET-CONFIG

Functions	Permission	Transparency
Set: NET-CONFIG	End User	Public
Get: NET-CONFIG?	End User	Public
Description	Syntax	
Set: Set a network configuration.	# NET-CONFIG <i>SP</i> <i>id,ip,net_mask,gateway</i> CR LF	
Get: Get a network configuration.	# NET-CONFIG? <i>SP</i> <i>id</i> CR LF	
Response		
Get: ~ <i>nn</i> @ NET-CONFIG <i>SP</i> <i>id,ip,net_mask,gateway</i> CR LF		
Parameters		
<i>id</i> – network ID <i>ip</i> – network IP <i>net_mask</i> – network mask <i>gateway</i> – network gateway		
K-Config Example		
"#NET-CONFIG 1,192.168.113.10,255.255.0.0,192.168.0.1",0x0D		

ETH-PORT

Functions	Permission	Transparency
Set: ETH-PORT	Administrator	Public
Get: ETH-PORT?	End User	Public
Description	Syntax	
Set: Set Ethernet port protocol	# ETH-PORT <i>SP</i> <i>portType,ETHPort</i> CR	
Get: Get Ethernet port protocol	# ETH-PORT? <i>SP</i> <i>portType</i> CR	
Response		
~ <i>nn</i> @ ETH-PORT <i>SP</i> <i>portType,ETHPort</i> CR LF		
Parameters		
<i>portType</i> – 0 (TCP), 1 (UDP) <i>ETHPort</i> – 0-65534 (TCP / UDP port number)		
Notes		
If the port number you enter is already in use, an error is returned. The port number must be within the following range: 2000-(2 ¹⁶ -1). UDP port 50001 and TCP port 5001 are reserved for internal use.		
K-Config Example		
Set the Ethernet port protocol for TCP to port 12457: "#ETH-PORT 0,12457",0x0D		

NET-DHCP

Functions		Permission	Transparency
Set:	NET-DHCP	Administrator	Public
Get:	NET-DHCP?	End User	Public
Description		Syntax	
Set:	Set DHCP mode	# NET-DHCP <i>SP</i> <i>mode</i> CR	
Get:	Get DHCP mode	# NET-DHCP? CR	
Response			
~ <i>nn</i> @ NET-DHCP <i>SP</i> <i>mode</i> CR LF			
Parameters			
<i>mode</i> – 0 (do not use DHCP. Use the IP address set by the factory or the NET-IP command), 1 (try to use DHCP. If unavailable, use the IP address set by the factory or the NET-IP command)			
Notes			
Connecting Ethernet to devices with DHCP may take more time in some networks To connect with a randomly assigned IP by DHCP, specify the device DNS name (if available) using the command "NAME". You can also get an assigned IP by direct connection to USB or RS-232 protocol port if available For proper settings consult your network administrator			
K-Config Example			
Enable DHCP mode, if available: "#NET-DHCP 1",0x0D			

NET-MAC?

Functions		Permission	Transparency
Set:	–	–	–
Get:	NET-MAC?	End User	Public
Description		Syntax	
Set:	–	–	
Get:	Get MAC address	# NET-MAC? CR	
Response			
~ <i>nn</i> @ NET-MAC <i>SP</i> <i>mac_address</i> CR LF			
Parameters			
<i>mac_address</i> – Unique MAC address. Format: XX-XX-XX-XX-XX-XX where X is hex digit			
K-Config Example			
"#NET-MAC?",0x0D			

The warranty obligations of Kramer Electronics Inc. ("Kramer Electronics") for this product are limited to the terms set forth below:

What is Covered

This limited warranty covers defects in materials and workmanship in this product.

What is Not Covered

This limited warranty does not cover any damage, deterioration or malfunction resulting from any alteration, modification, improper or unreasonable use or maintenance, misuse, abuse, accident, neglect, exposure to excess moisture, fire, improper packing and shipping (such claims must be presented to the carrier), lightning, power surges, or other acts of nature. This limited warranty does not cover any damage, deterioration or malfunction resulting from the installation or removal of this product from any installation, any unauthorized tampering with this product, any repairs attempted by anyone unauthorized by Kramer Electronics to make such repairs, or any other cause which does not relate directly to a defect in materials and/or workmanship of this product. This limited warranty does not cover cartons, equipment enclosures, cables or accessories used in conjunction with this product.

Without limiting any other exclusion herein, Kramer Electronics does not warrant that the product covered hereby, including, without limitation, the technology and/or integrated circuit(s) included in the product, will not become obsolete or that such items are or will remain compatible with any other product or technology with which the product may be used.

How Long this Coverage Lasts

The standard limited warranty for Kramer products is seven (7) years from the date of original purchase, with the following exceptions:

1. All Kramer VIA hardware products are covered by a standard three (3) year warranty for the VIA hardware and a standard three (3) year warranty for firmware and software updates.
2. All Kramer fiber optic cables, adapter-size fiber optic extenders, active cables, cable retractors, all Kramer speakers and Kramer touch panels are covered by a standard one (1) year warranty.
3. All Kramer Cobra products, all Kramer Calibre products, all Kramer Minicom digital signage products, all HighSecLabs products, all streaming, and all wireless products are covered by a standard three (3) year warranty.
4. All Sierra Video MultiViewers are covered by a standard five (5) year warranty.
5. Sierra switchers & control panels are covered by a standard seven (7) year warranty (excluding power supplies and fans that are covered for three (3) years).
6. K-Touch software is covered by a standard one (1) year warranty for software updates.
7. All Kramer passive cables are covered by a ten (10) year warranty.

Who is Covered

Only the original purchaser of this product is covered under this limited warranty. This limited warranty is not transferable to subsequent purchasers or owners of this product.

What Kramer Electronics Will Do

Kramer Electronics will, at its sole option, provide one of the following three remedies to whatever extent it shall deem necessary to satisfy a proper claim under this limited warranty:

1. Elect to repair or facilitate the repair of any defective parts within a reasonable period of time, free of any charge for the necessary parts and labor to complete the repair and restore this product to its proper operating condition. Kramer Electronics will also pay the shipping costs necessary to return this product once the repair is complete.
2. Replace this product with a direct replacement or with a similar product deemed by Kramer Electronics to perform substantially the same function as the original product.
3. Issue a refund of the original purchase price less depreciation to be determined based on the age of the product at the time remedy is sought under this limited warranty.

What Kramer Electronics Will Not Do Under This Limited Warranty

If this product is returned to Kramer Electronics or the authorized dealer from which it was purchased or any other party authorized to repair Kramer Electronics products, this product must be insured during shipment, with the insurance and shipping charges prepaid by you. If this product is returned uninsured, you assume all risks of loss or damage during shipment. Kramer Electronics will not be responsible for any costs related to the removal or re-installation of this product from or into any installation. Kramer Electronics will not be responsible for any costs related to any setting up this product, any adjustment of user controls or any programming required for a specific installation of this product.

How to Obtain a Remedy Under This Limited Warranty

To obtain a remedy under this limited warranty, you must contact either the authorized Kramer Electronics reseller from whom you purchased this product or the Kramer Electronics office nearest you. For a list of authorized Kramer Electronics resellers and/or Kramer Electronics authorized service providers, visit our web site at www.kramerav.com or contact the Kramer Electronics office nearest you.

In order to pursue any remedy under this limited warranty, you must possess an original, dated receipt as proof of purchase from an authorized Kramer Electronics reseller. If this product is returned under this limited warranty, a return authorization number, obtained from Kramer Electronics, will be required (RMA number). You may also be directed to an authorized reseller or a person authorized by Kramer Electronics to repair the product.

If it is decided that this product should be returned directly to Kramer Electronics, this product should be properly packed, preferably in the original carton, for shipping. Cartons not bearing a return authorization number will be refused.

Limitation of Liability

THE MAXIMUM LIABILITY OF KRAMER ELECTRONICS UNDER THIS LIMITED WARRANTY SHALL NOT EXCEED THE ACTUAL PURCHASE PRICE PAID FOR THE PRODUCT. TO THE MAXIMUM EXTENT PERMITTED BY LAW, KRAMER ELECTRONICS IS NOT RESPONSIBLE FOR DIRECT, SPECIAL, INCIDENTAL OR CONSEQUENTIAL DAMAGES RESULTING FROM ANY BREACH OF WARRANTY OR CONDITION, OR UNDER ANY OTHER LEGAL THEORY. Some countries, districts or states do not allow the exclusion or limitation of relief, special, incidental, consequential or indirect damages, or the limitation of liability to specified amounts, so the above limitations or exclusions may not apply to you.

Exclusive Remedy

TO THE MAXIMUM EXTENT PERMITTED BY LAW, THIS LIMITED WARRANTY AND THE REMEDIES SET FORTH ABOVE ARE EXCLUSIVE AND IN LIEU OF ALL OTHER WARRANTIES, REMEDIES AND CONDITIONS, WHETHER ORAL OR WRITTEN, EXPRESS OR IMPLIED. TO THE MAXIMUM EXTENT PERMITTED BY LAW, KRAMER ELECTRONICS SPECIFICALLY DISCLAIMS ANY AND ALL IMPLIED WARRANTIES, INCLUDING, WITHOUT LIMITATION, WARRANTIES OF MERCHANTABILITY AND FITNESS FOR A PARTICULAR PURPOSE. IF KRAMER ELECTRONICS CANNOT LAWFULLY DISCLAIM OR EXCLUDE IMPLIED WARRANTIES UNDER APPLICABLE LAW, THEN ALL IMPLIED WARRANTIES COVERING THIS PRODUCT, INCLUDING WARRANTIES OF MERCHANTABILITY AND FITNESS FOR A PARTICULAR PURPOSE, SHALL APPLY TO THIS PRODUCT AS PROVIDED UNDER APPLICABLE LAW. IF ANY PRODUCT TO WHICH THIS LIMITED WARRANTY APPLIES IS A "CONSUMER PRODUCT" UNDER THE MAGNUSON-MOSS WARRANTY ACT (15 U.S.C.A. §2301, ET SEQ.) OR OTHER APPLICABLE LAW, THE FOREGOING DISCLAIMER OF IMPLIED WARRANTIES SHALL NOT APPLY TO YOU, AND ALL IMPLIED WARRANTIES ON THIS PRODUCT, INCLUDING WARRANTIES OF MERCHANTABILITY AND FITNESS FOR THE PARTICULAR PURPOSE, SHALL APPLY AS PROVIDED UNDER APPLICABLE LAW.

Other Conditions

This limited warranty gives you specific legal rights, and you may have other rights which vary from country to country or state to state.

This limited warranty is void if (i) the label bearing the serial number of this product has been removed or defaced, (ii) the product is not distributed by Kramer Electronics or (iii) this product is not purchased from an authorized Kramer Electronics reseller. If you are unsure whether a reseller is an authorized Kramer Electronics reseller, visit our web site at www.kramerav.com or contact a Kramer Electronics office from the list at the end of this document.

Your rights under this limited warranty are not diminished if you do not complete and return the product registration form or complete and submit the online product registration form. Kramer Electronics thanks you for purchasing a Kramer Electronics product. We hope it will give you years of satisfaction.



SAFETY WARNING

Disconnect the unit from the power supply before opening and servicing

For the latest information on our products and a list of Kramer distributors, visit our Web site where updates to this user manual may be found.

We welcome your questions, comments, and feedback.